

TechnoPanel-Screen

The High-End Sliding Panels by TechnoShade

(Indoor Panel Screen)

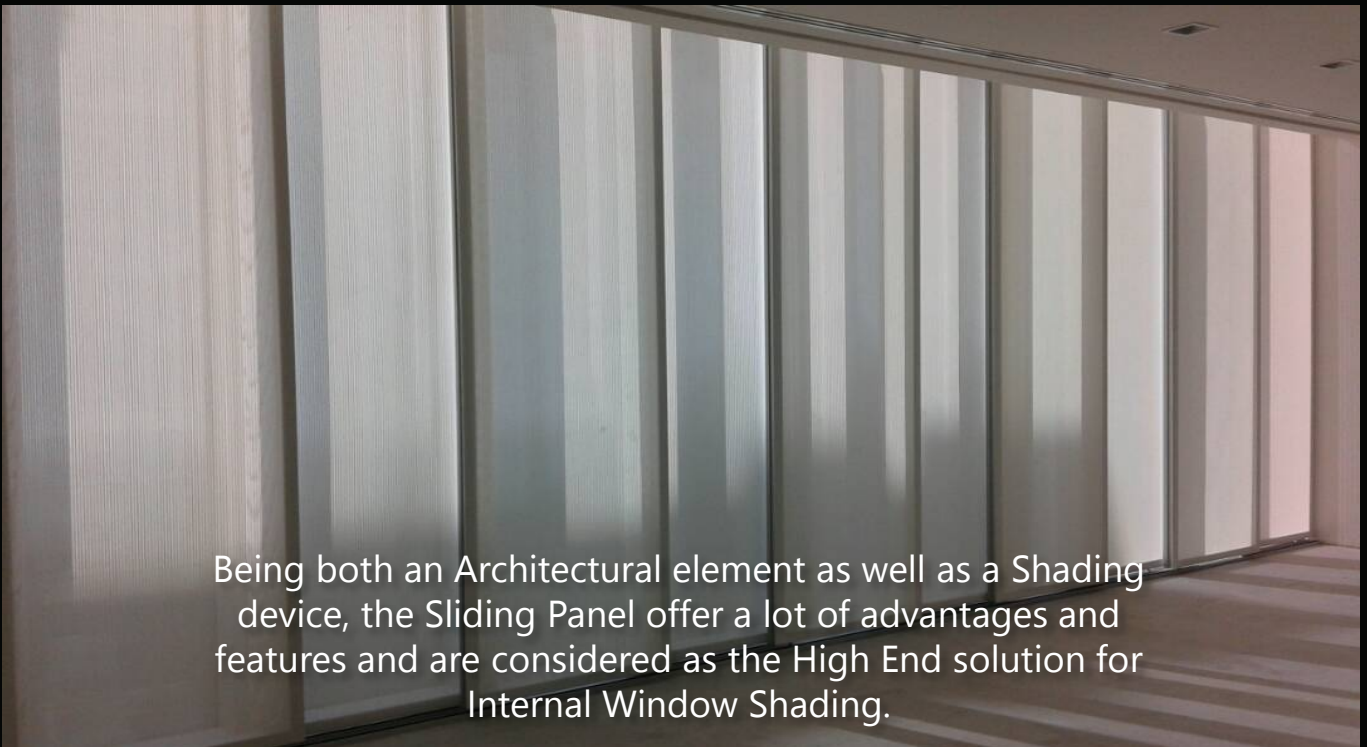

Smart Shading Solutions for Sustainable Architecture

The High-End Sliding Panels by TechnoShade

Description:

The TechnoPanel-Screen is a sliding shutter made of aluminum and Tensioned Fabric

The TechnoPanel-Screen is made of 4 main components: Frame / Fabric / Upper Hardware / Lower Hardware

Application:

Ideal for façades with a high proportion of glass, wherever screening and shade form part of the façade design, and where space is at a premium, e.g. schools, hotels, public buildings, office and administration premises, apartment buildings, low-energy houses, etc.

Hardware and Aluminum upper & lower guides:

This includes all the Rollers and other high-end accessories especially designed for External Sliding shutter. This Hardware system allows the Shutters to be properly operated and placed, parallel to the front of the window.

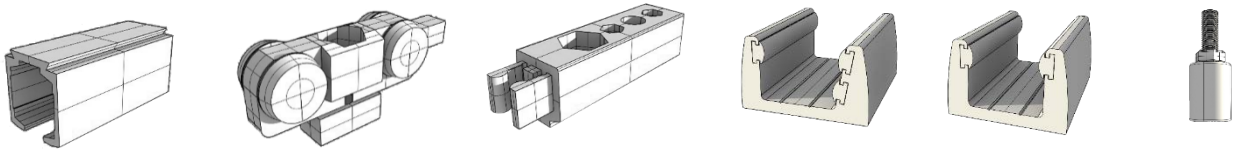

Sections:

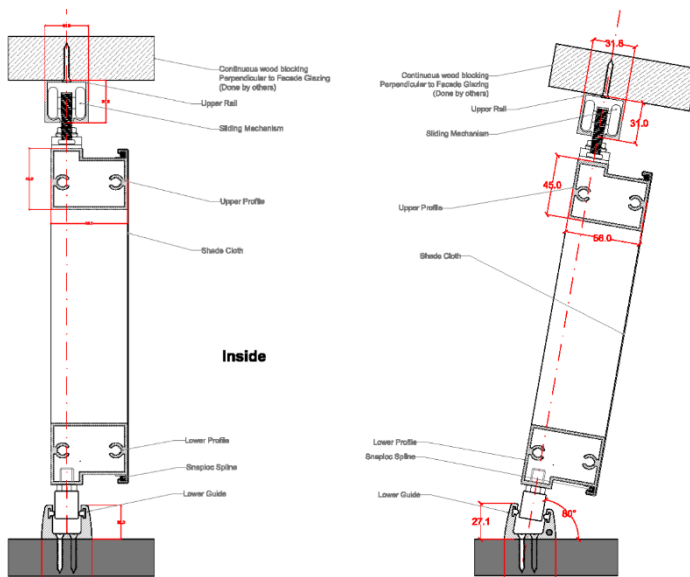

Optional Motorization:

In addition to standard manual operation, Motorization is available through a state-of-the-art system that can be manually overridden

TechnoPanel-Screen

The High-End Sliding Panels by TechnoShade

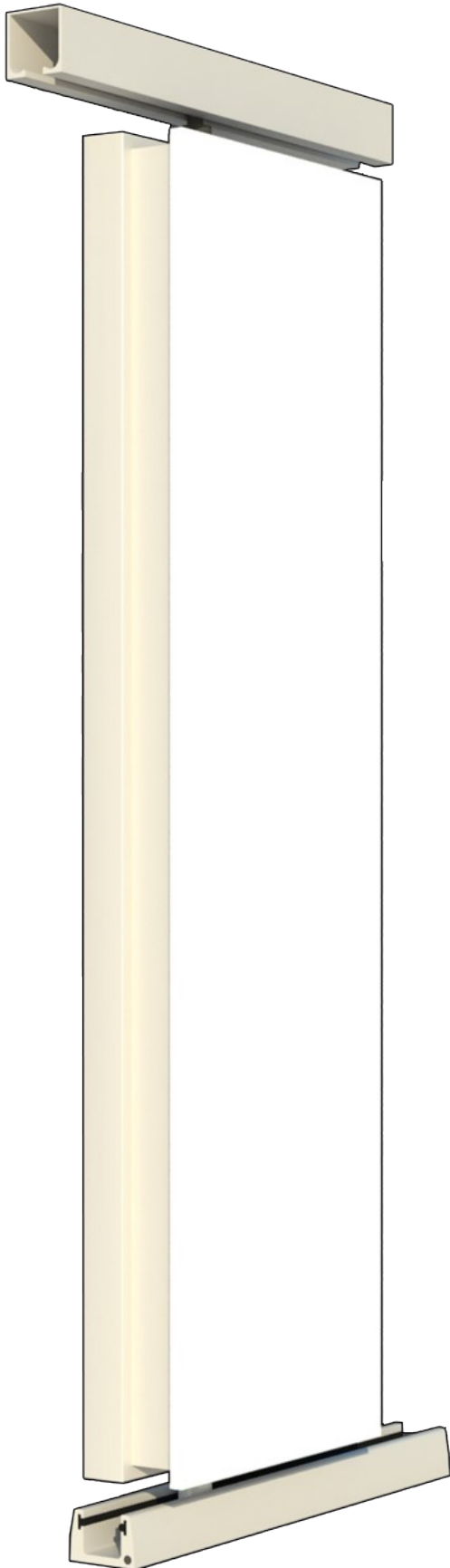

- Silent Sliding Screen
- Minimal Esthetic Design
for internal Architecture
- Snap On Fixation
- Easy Installation and Dismantling

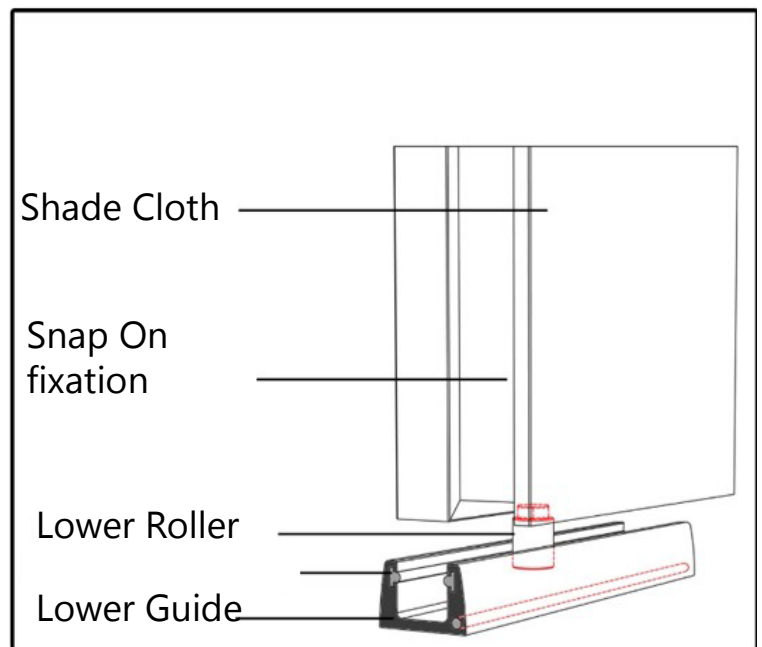
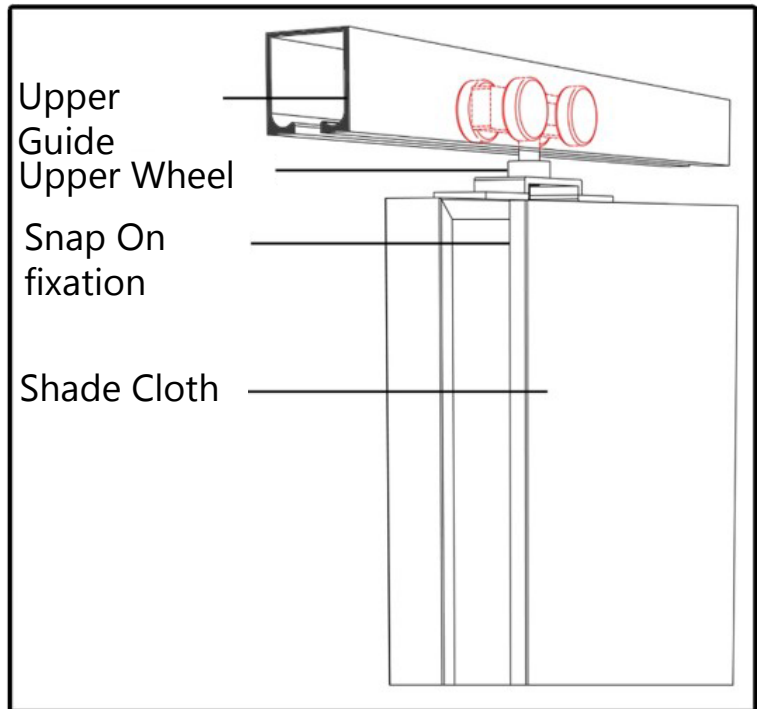



Through an overall approach to Sustainable Development, combining “bioclimatic principles” with both comfort to the occupant and refined Architecture, TechnoShade is a leading company involved in “Sustainable Architecture” through providing a variety of Smart Window Solutions. Our Automated Roller Shades, our Elegant Skylight Shades, our See-through Roller Shutters, our Smart & Motorized Louvers are all “energy-efficient” Architectural elements dedicated to form a “Dynamic Facade” and contribute in optimizing the energy performance of a building.

Our external Zipper Flyscreen offers to the tenants the possibility of ventilating their interior without having insects in. The Convertible Umbrellas and Pergolas Shadings are dedicated to provide additional living space and comfort.

TechnoShade has a 20-year experienced team following up all the different phases of making a smart building; from preliminary design to execution details followed by implementation and configuration.

TechnoShade has contributed in the realization of many projects in different applications such as residential towers, hospitals, administrative buildings, universities and hotels among them many are LEED certified.

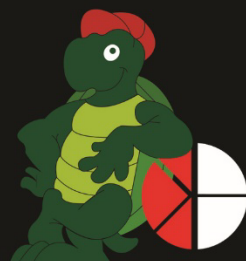

TechnoShade[®]
Natural Light Management™
www.technoshade.com